

SERVICE REPAIR

MANUAL

Hyster A478 (C60Z) Forklift

HYSTER

DIAGRAMS

T5Z [A476];
T7Z [A477];
C60Z [A478];
C80Z [A479];
T5Z^{AC} [B476];
T7Z^{AC} [B477];
C60Z^{AC} [B478];
C80Z^{AC} [B479]

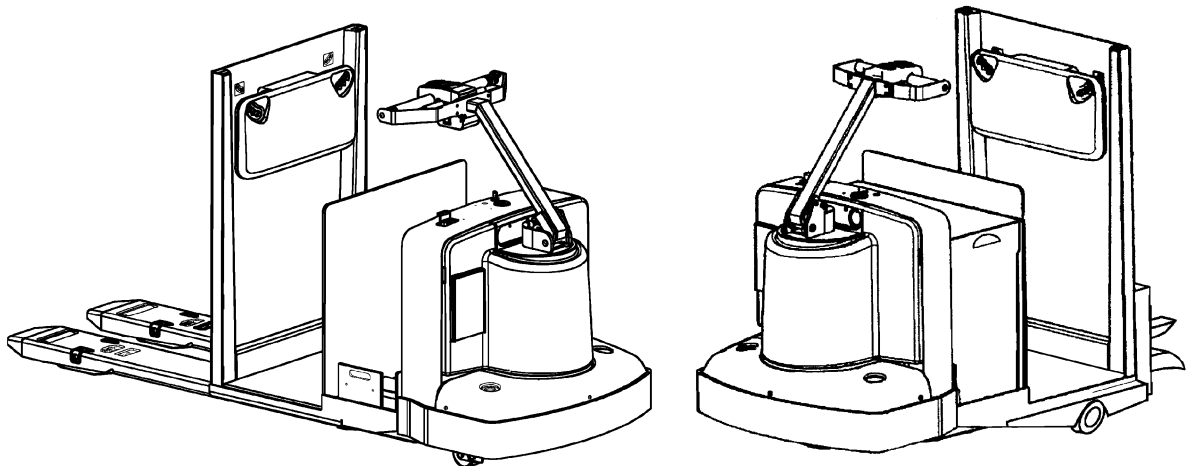

HYSTER

SAFETY PRECAUTIONS

MAINTENANCE AND REPAIR

- When lifting parts or assemblies, make sure all slings, chains, or cables are correctly fastened, and that the load being lifted is balanced. Make sure the crane, cables, and chains have the capacity to support the weight of the load.
- Do not lift heavy parts by hand, use a lifting mechanism.
- Wear safety glasses.
- DISCONNECT THE BATTERY CONNECTOR before doing any maintenance or repair on electric lift trucks. Disconnect the battery ground cable on internal combustion lift trucks.
- Always use correct blocks to prevent the unit from rolling or falling. See HOW TO PUT THE LIFT TRUCK ON BLOCKS in the **Operating Manual** or the **Periodic Maintenance** section.
- Keep the unit clean and the working area clean and orderly.
- Use the correct tools for the job.
- Keep the tools clean and in good condition.
- Always use **HYSTER APPROVED** parts when making repairs. Replacement parts must meet or exceed the specifications of the original equipment manufacturer.
- Make sure all nuts, bolts, snap rings, and other fastening devices are removed before using force to remove parts.
- Always fasten a DO NOT OPERATE tag to the controls of the unit when making repairs, or if the unit needs repairs.
- Be sure to follow the **WARNING** and **CAUTION** notes in the instructions.
- Gasoline, Liquid Petroleum Gas (LPG), Compressed Natural Gas (CNG), and Diesel fuel are flammable. Be sure to follow the necessary safety precautions when handling these fuels and when working on these fuel systems.
- Batteries generate flammable gas when they are being charged. Keep fire and sparks away from the area. Make sure the area is well ventilated.

NOTE: The following symbols and words indicate safety information in this manual:



WARNING

Indicates a condition that can cause immediate death or injury!



CAUTION

Indicates a condition that can cause property damage!

On the lift truck, the WARNING symbol and word are on orange background. The CAUTION symbol and word are on yellow background.

TABLE OF CONTENTS

Diagrams, Schematics, or Arrangements	1
T5-7Z.....	1
Figure 1. Wiring Schematic.....	2
Figure 2. Wiring Diagram	4
C60-80Z.....	5
Figure 3. Schematic Diagram - 24V "E" SEM Control.....	6
Figure 4. Schematic Diagram - 24V "E" SEM Control.....	7
Figure 5. Schematic Diagram - 24V "E" SEM Control.....	8
Figure 6. Hydraulic Schematic (C60Z and C60Z ^{AC}).....	9
Figure 7. Hydraulic Schematic (C80Z and C80Z ^{AC}).....	10
T5-7Z ^{AC}	10
Figure 8. Schematic / Wiring Diagrams.....	11
C60-80Z ^{AC}	18
Figure 9. Schematic / Wiring Diagrams.....	19

This section is for the following models:

T5Z [A476];
 T7Z [A477];
 C60Z [A478];
 C80Z [A479];
 T5Z^{AC} [B476];
 T7Z^{AC} [B477];
 C60Z^{AC} [B478];
 C80Z^{AC} [B479]

**"THE
QUALITY
KEEPERS"**

**HYSTER
APPROVED
PARTS**

**Thanks very much for your reading,
Want to get more information,
Please click here, Then get the complete
manual**

JustClickHere 

NOTE:

**If there is no response to click on the link above,
please download the PDF document first, and then
click on it.**

**Have any questions please write to me:
admin@servicemanualperfect.com**

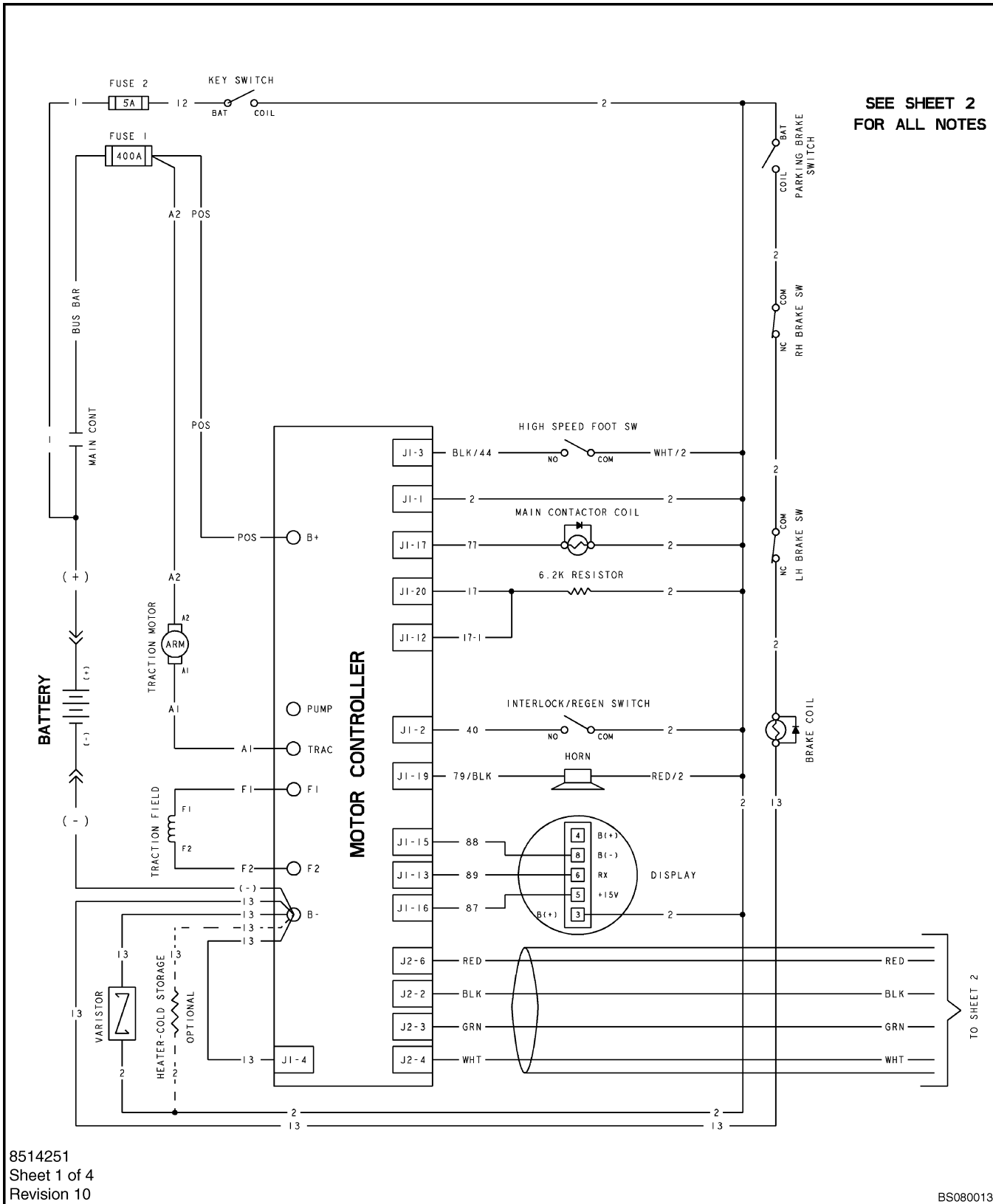

8514251
 Sheet 1 of 4
 Revision 10

BS080013

GENERAL NOTES:

- ALL PARTS ARE SHOWN IN THE NORMAL POSITION FOR THE FOLLOWING CONDITIONS:
UNIT STOPPED,
OPERATOR IS OFF THE UNIT,
BATTERY DISCONNECTED.
- "REVERSE" IS TRAVEL IN THE DIRECTION OF THE FORKS.
- CHAIN LINES INDICATE "EE" ENCLOSURE.
- BROKEN LINES ARE FOR OPTION ONLY.
- ALL UNUSED TERMINALS AND CONNECTORS MUST BE SECURE TO A MAIN WIRE HARNESS BRANCH.
- ALL CONNECTORS ARE DRAWN FROM FRONT VIEW AND ARE ENLARGED FOR CLARITY.

◻ CONNECTOR(S) OR WIRE(S) NOT USED ON THIS MODEL

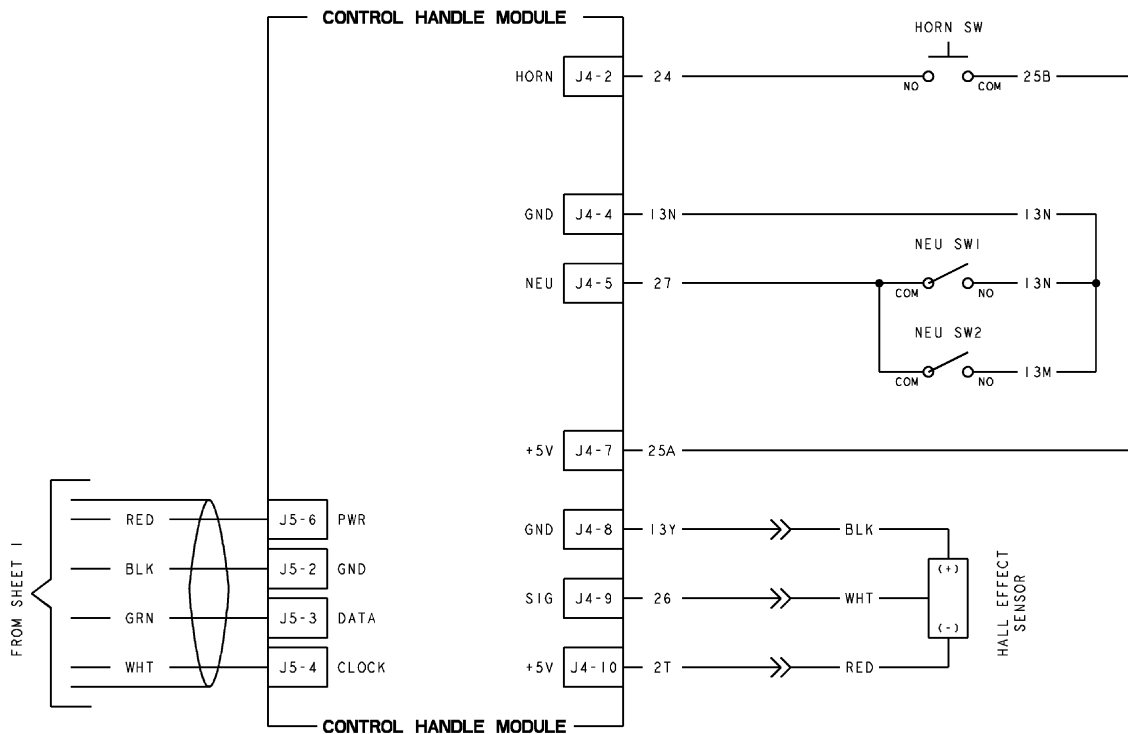

8514251
Sheet 2 of 4
Revision 10

BS080014

Figure 1. Wiring Schematic

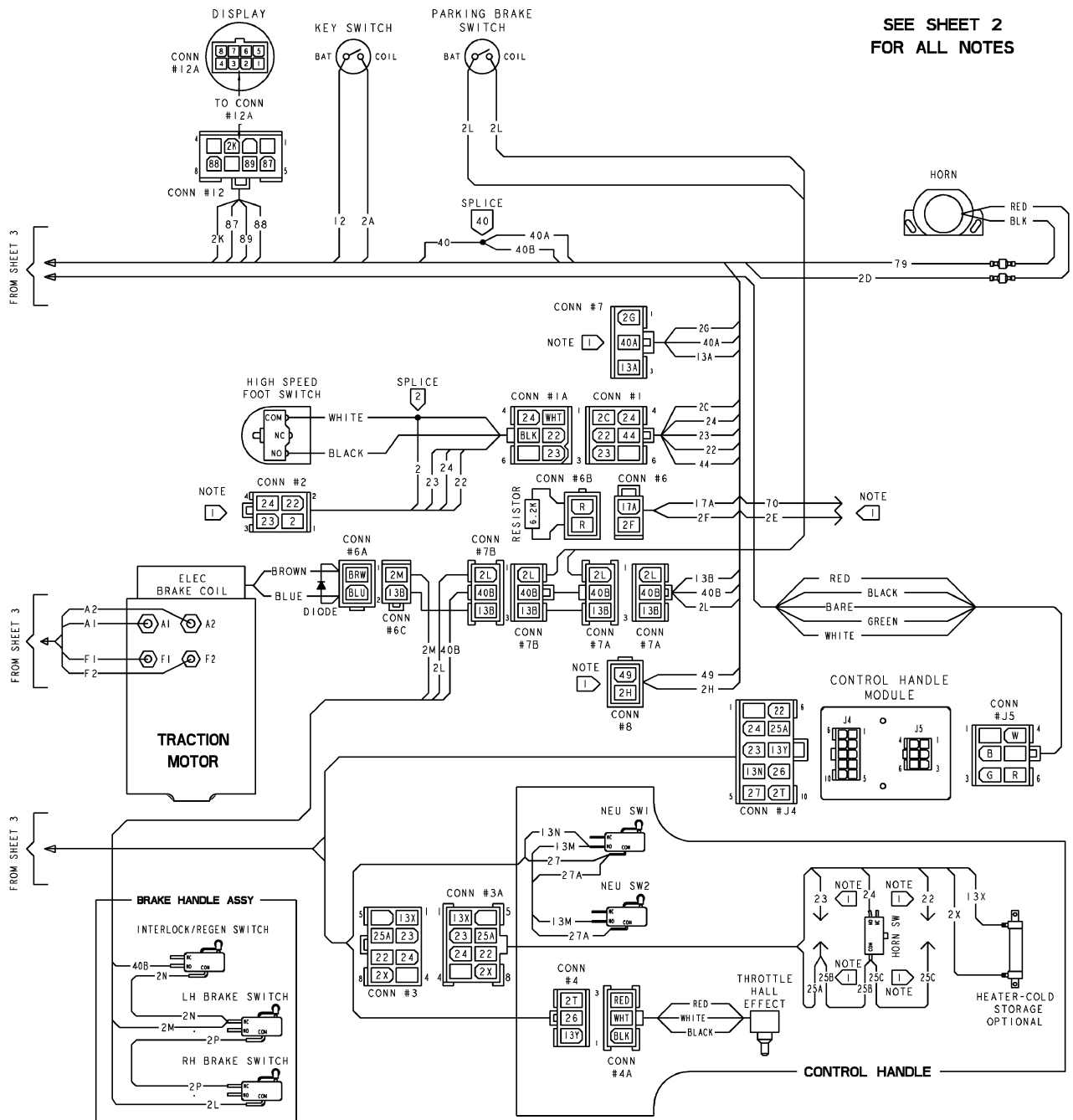

SEE SHEET 2
FOR ALL NOTES

8514251
Sheet 4 of 4
Revision 10

BS080042

Figure 2. Wiring Diagram

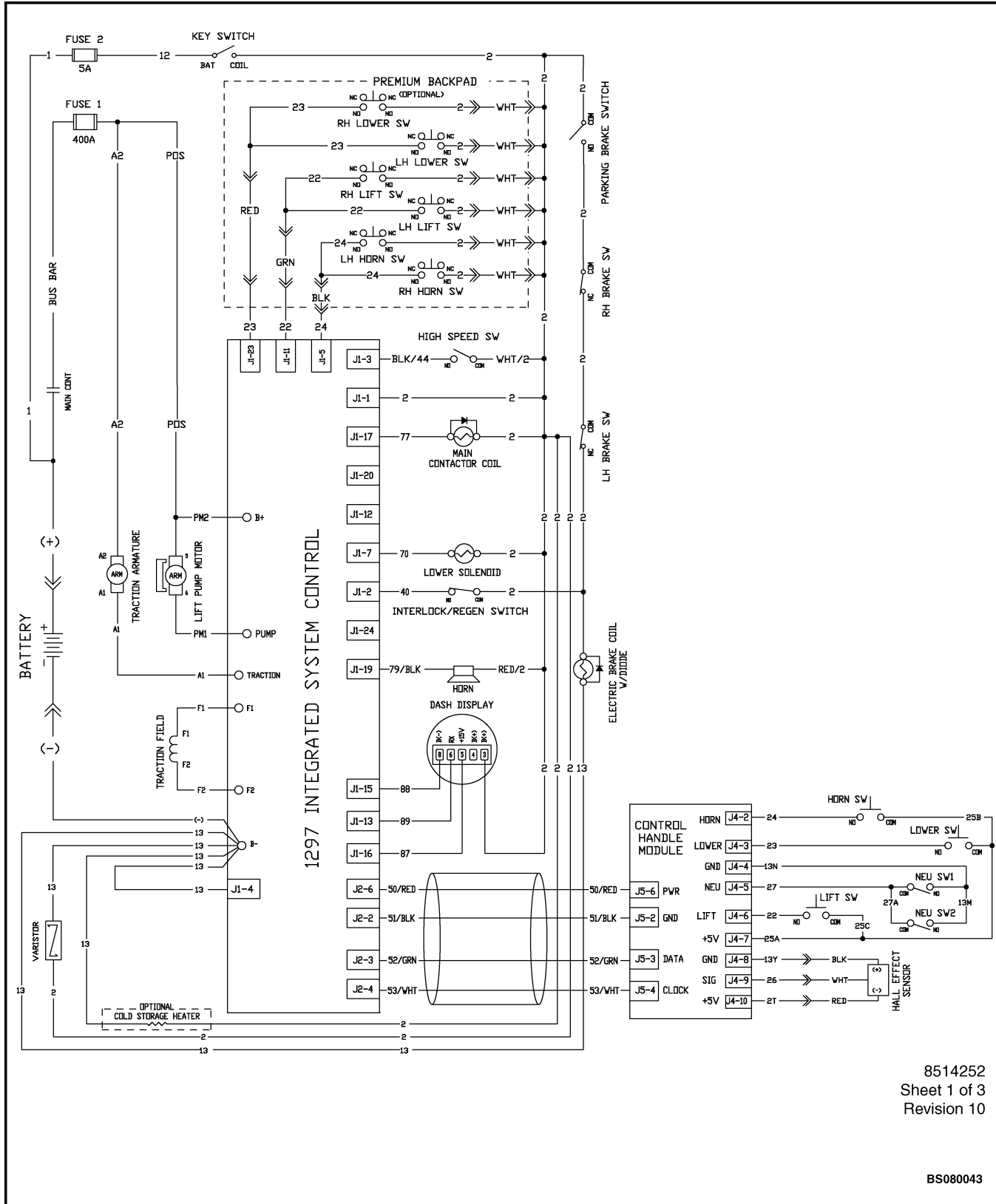
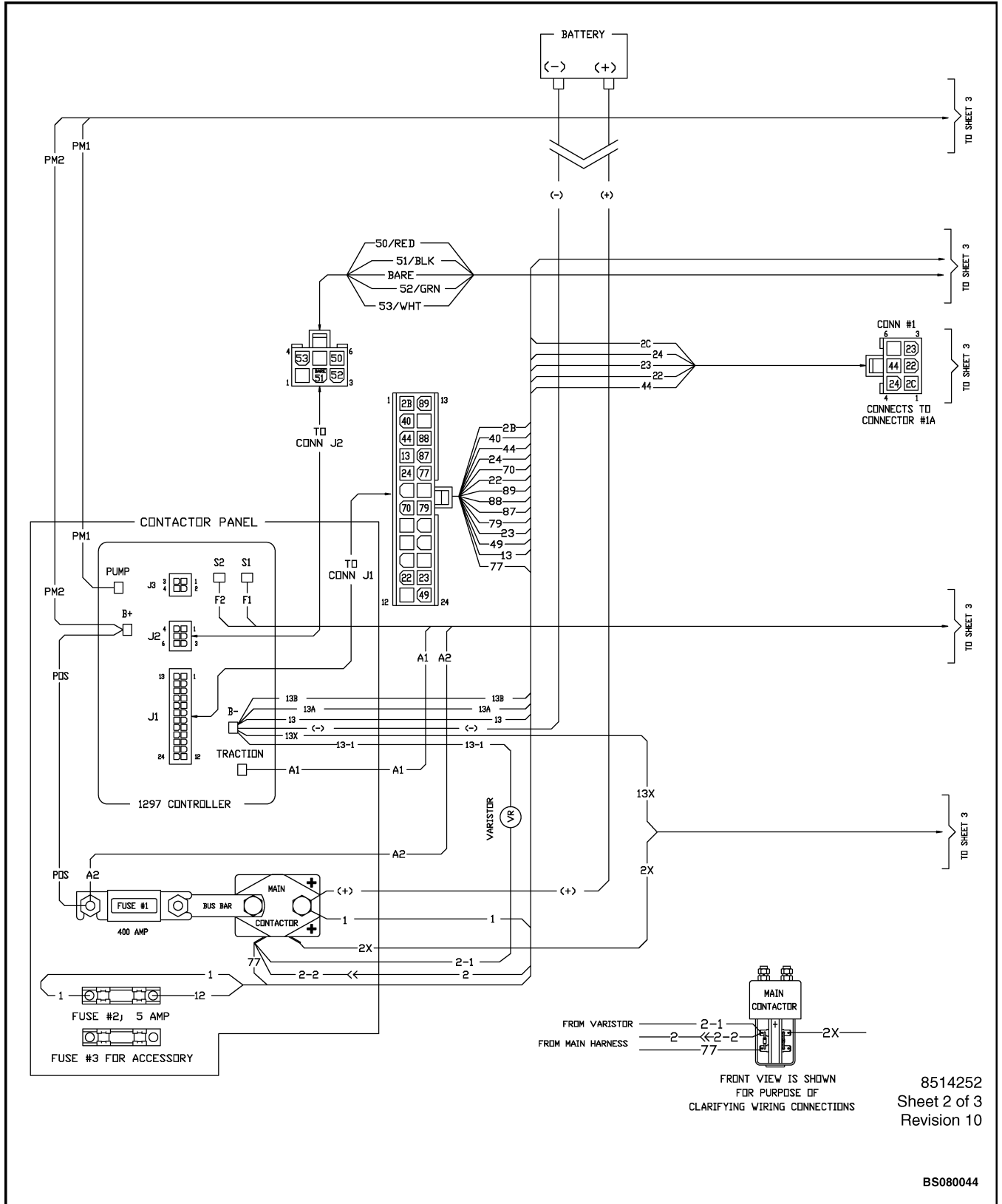

Figure 3. Schematic Diagram - 24V "E" SEM Control

8514252
 Sheet 1 of 3
 Revision 10

BS080043



FRONT VIEW IS SHOWN FOR PURPOSE OF CLARIFYING WIRING CONNECTIONS

8514252
Sheet 2 of 3
Revision 10

BS080044

Figure 4. Schematic Diagram - 24V "E" SEM Control

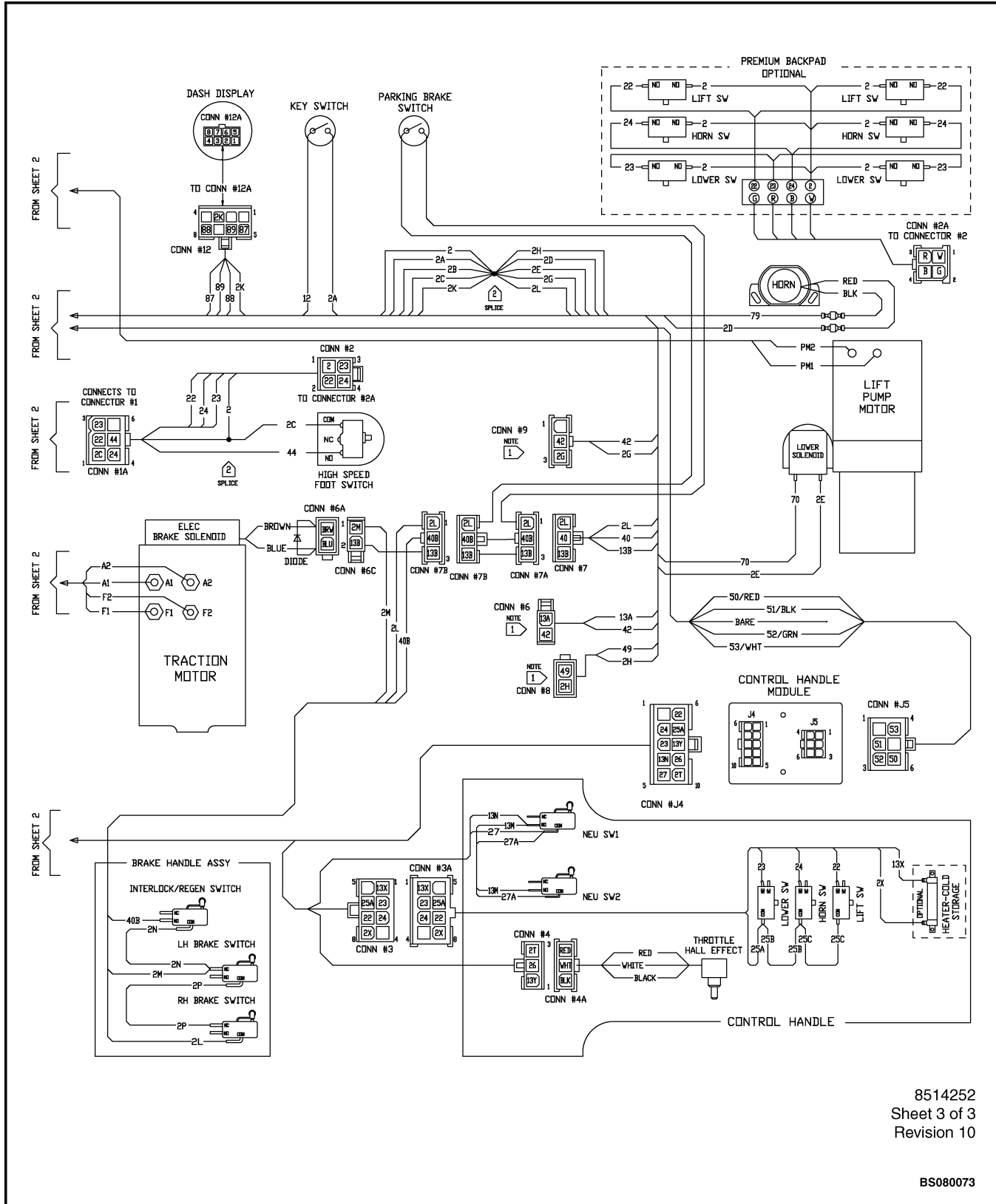

8514252
Sheet 3 of 3
Revision 10

BS080073

Figure 5. Schematic Diagram - 24V "E" SEM Control

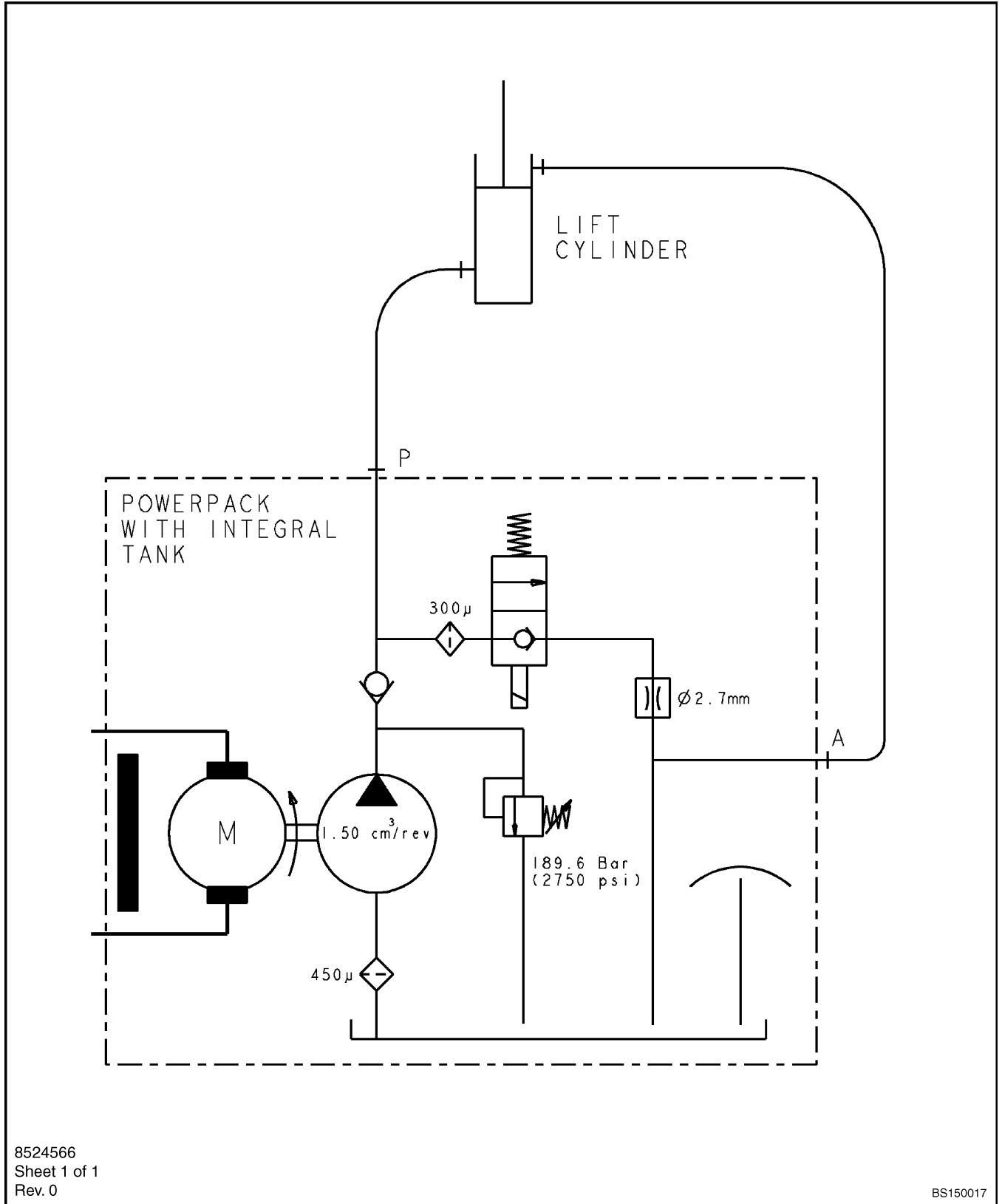

8524566
Sheet 1 of 1
Rev. 0

BS150017

Figure 6. Hydraulic Schematic (C60Z and C60Z^{AC})

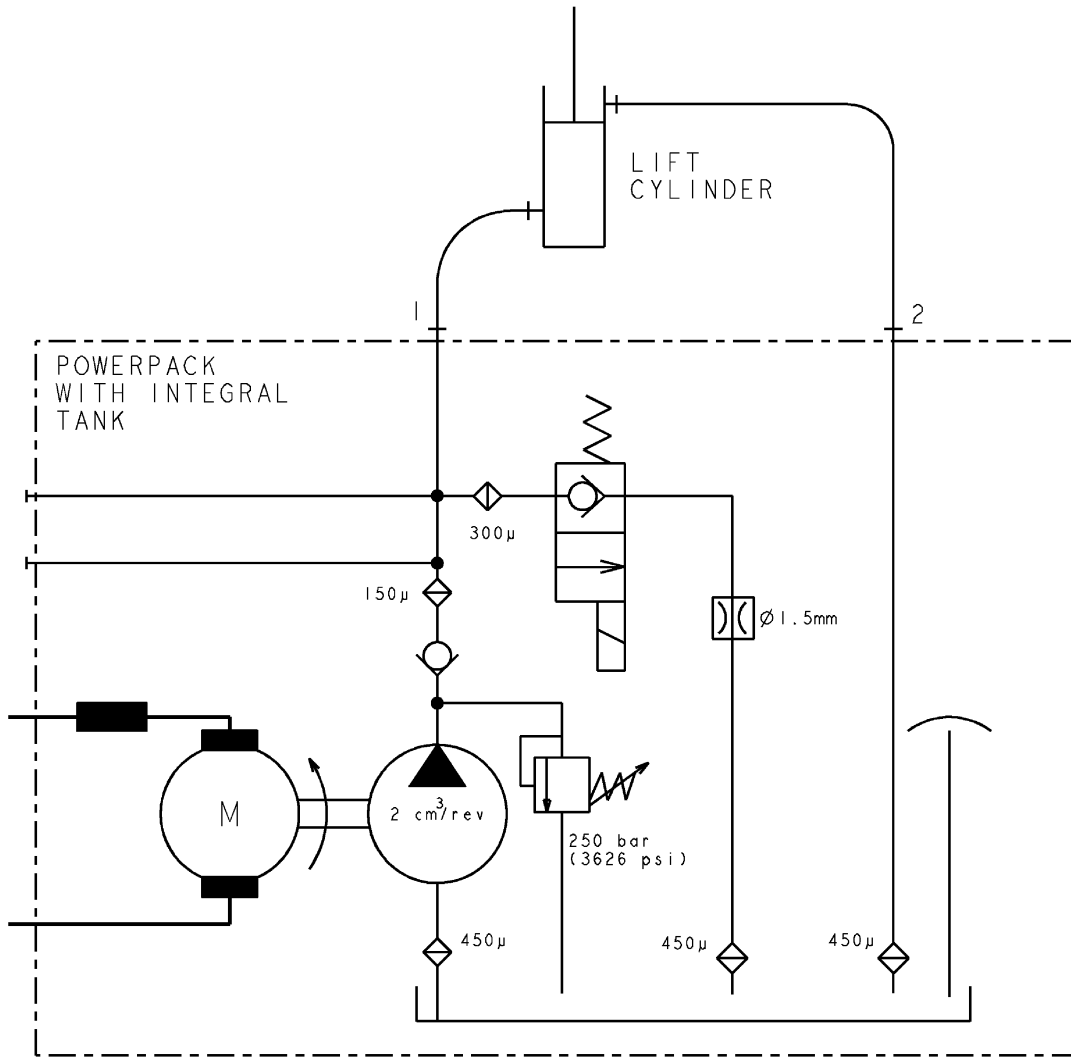

8524569
Sheet 1 of 1
Rev. 0

BS150018

Figure 7. Hydraulic Schematic (C80Z and C80Z^{AC})

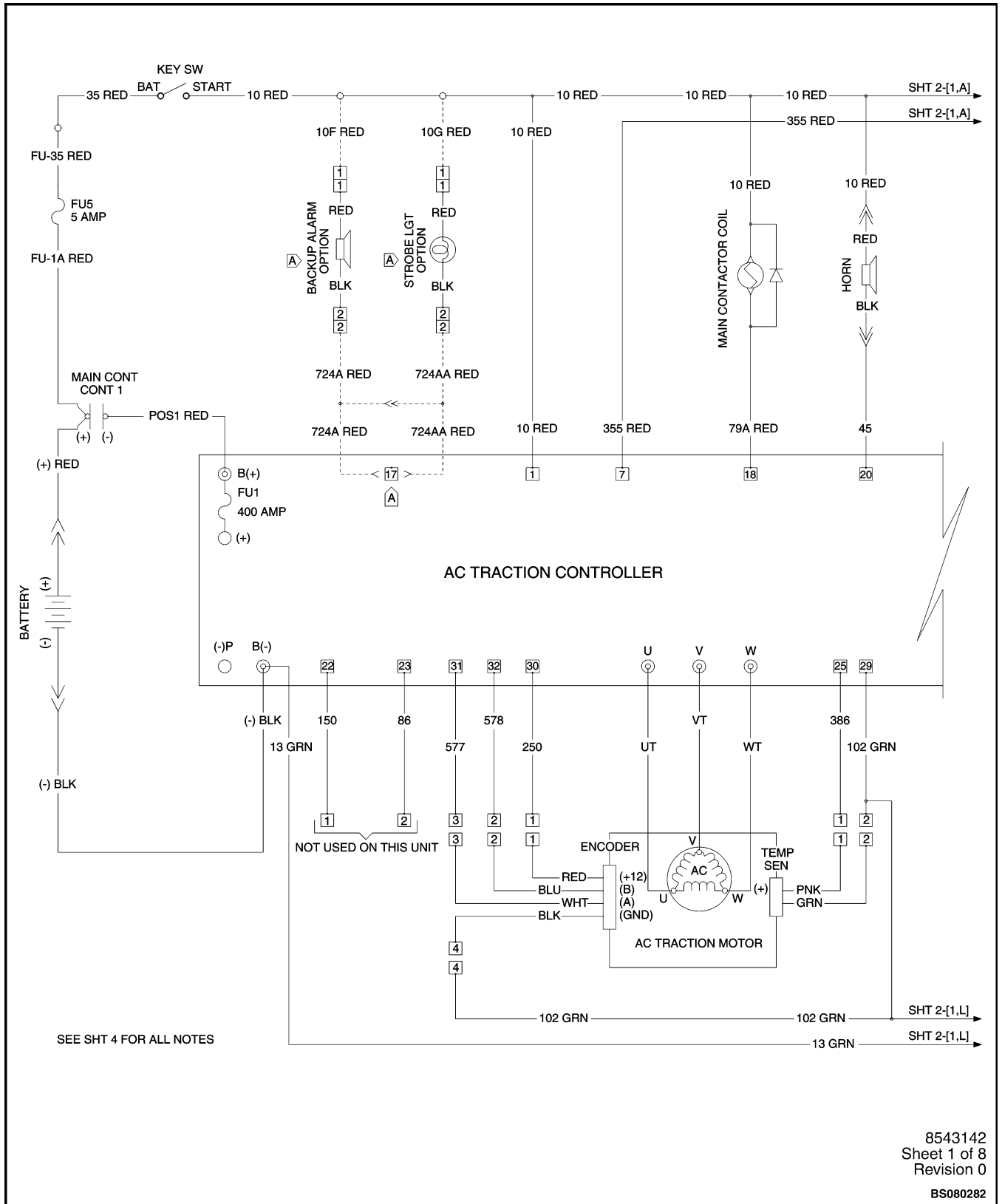

Figure 8. Schematic / Wiring Diagrams (Sheet 1 of 8)

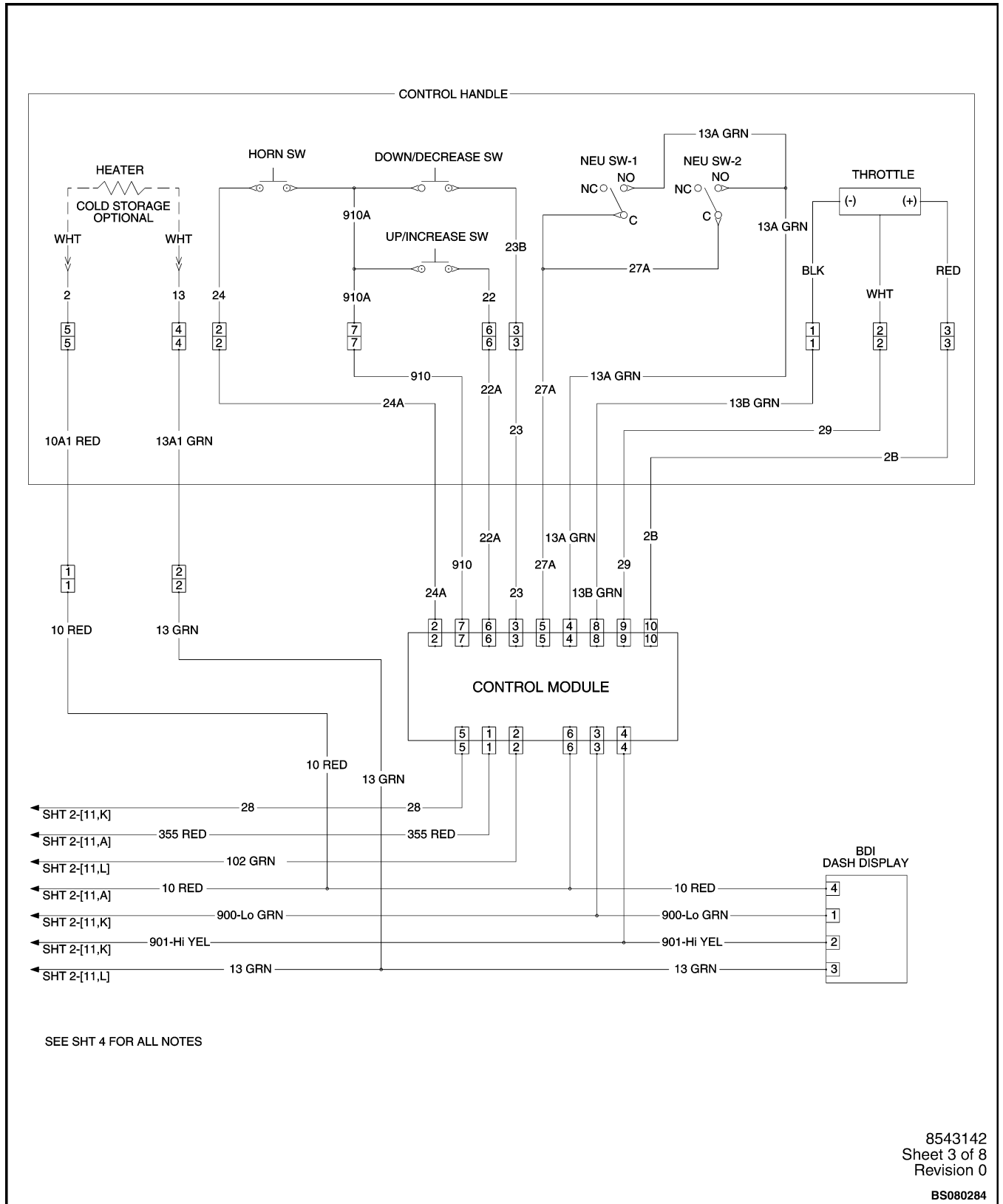

Figure 8. Schematic / Wiring Diagrams (Sheet 3 of 8)

GENERAL NOTES:

ALL PARTS ARE SHOWN IN THE NORMAL POSITION, FOR THE FOLLOWING CONDITION:

- UNIT STOPPED
- BATTERY DISCONNECTED
- OPERATOR IS OFF THE UNIT
- STEERING IS SET FOR STRAIGHT TRAVEL
- ALL SWITCHES ARE SHOWN IN THE STATIC POSITION
- ALL WIRES ARE WHITE UNLESS OTHERWISE NOTED
- ALL POWER CABLES ARE BLACK UNLESS OTHERWISE NOTED
- REVERSE IS TRAVEL IN DIRECTION OF THE FORKS
- CHAIN LINES INDICATE "EE" ENCLOSURE
- DASH LINES INDICATE OPTIONAL EQUIPMENT

YOUR UNIT MODEL MAY NOT HAVE ALL THE OPTIONS SHOWN IN THIS SCHEMATIC - WIRING DIAGRAM. SEE SCHEMATIC - WIRING DIAGRAM FOR EACH CONFIGURATION TO DETERMINE EXACT CONTENT.

ALL UNUSED TERMINALS AND CONNECTORS MUST BE SECURE TO A MAIN WIRE HARNESS.

FOR PROPER UNIT OPERATION FOLLOWING STEPS MUST BE TAKEN, OBSERVED AND FOLLOW. SEE INSTRUCTION NOTES ON THIS PAGE.

CIRCUIT I.D. LEGEND:

AMB	AMBER	ORN	ORANGE
BLK	BLACK	PNK	PINK
BLU	BLUE	PPL	PURPLE
BRN	BROWN	RED	RED
CLER	CLEAR	VLT	VIOLENT
GRA	GRAY	WHT	WHITE
GRN	GREEN	YEL	YELLOW
NAT	NATURAL		

CONNECTOR AND TERMINAL NAMING CONVENTION:

CRP88	CPS88
C = CONNECTOR	C = CONNECTOR
R = RECEPTACLE	P = PLUG
P = PIN	S = SOCKET
88 = SEQUENTIAL NUMBER	88 = SEQUENTIAL NUMBER
TR88	TFK88
T = TERMINAL	T = TERMINAL
R = RING	FK = FORK
88 = SEQUENTIAL NUMBER	88 = SEQUENTIAL NUMBER
TBM/F88	TM/F88
T = TERMINAL	T = TERMINAL
B = BULET	M/F = MALE OR FEMALE
M/F = MALE OR FEMALE	88 = SEQUENTIAL NUMBER
88 = SEQUENTIAL NUMBER	

CAN BUSS CIRCUIT I.D.

TWISTED PAIR - WHITE = CAN HI CKT 901
 TWISTED PAIR - BLACK = CAN LO CKT 900
 UNLESS OTHERWISE NOTED.

CBL88/901 HI WHT
 CBL = CABLE
 88 = SEQUENTIAL NUMBER
 901 HI = BAN BUSS CIRCUIT
 WHT = COLOR OF INTERNAL CONDUCTOR/S

A INSTRUCTION NOTES:

FOR PROPER TRUCK OPERATION FOLLOW FOLLOWING INSTRUCTIONS:

TRUCK EQUIPPED WITH BACKUP ALARM:

- CONNECT CONNECTOR CPS133 WITH CONNECTOR VCRP133, WHICH IS PART OF BACKUP ALARM ASSEMBLY.
- ROUTE WIRES FROM CONNECTOR CPS133 AS FOLLOWS:
 - ROUTE WIRE W10-F RED TO KEY SWITCH AND CONNECT TO "START" POSITION.
 - ROUTE WIRE W724-A RED ALONG THE MAIN WIRE HARNESS TO CONNECTOR CPS05 ON AC CONTROLLER AND INSERT INTO CONNECTOR CPS05, POSITION 17.
 - USE TY-WRAPS TO SECURE BOTH WIRES TO THE MAIN WIRE HARNESS.

CONDITION SETTING INSTRUCTIONS:

- ENTER TECHNICIAN PROGRAMMING MANU.
- GO TO GENERAL ITEMS.
- SET TO ACCESSORY CONDITION.
- SAVE AND EXIT.

TRUCK EQUIPPED WITH STROBE LIGHT:

- CONNECT CONNECTOR CPS135 WITH CONNECTOR VCRP135, WHICH IS PART OF STROBE LIGHT ASSEMBLY.
- ROUTE WIRES FROM CONNECTOR CPS135 AS FOLLOWS:
 - ROUTE WIRE W10-G RED TO KEY SWITCH AND CONNECT TO "START" POSITION.
 - ROUTE WIRE W724-AA RED ALONG THE MAIN WIRE HARNESS TO CONNECTOR CPS05 ON AC CONTROLLER AND INSERT INTO CONNECTOR CPS05, POSITION 17.
 - USE TY-WRAPS TO SECURE BOTH WIRES TO THE MAIN WIRE HARNESS.

CONDITION SETTING INSTRUCTIONS:

- ENTER TECHNICIAN PROGRAMMING MANU.
- GO TO GENERAL ITEMS.
- SET TO ACCESSORY CONDITION.
- SAVE AND EXIT.

TRUCK EQUIPPED WITH BACKUP ALARM AND STROBE LIGHT:

- CONNECT CONNECTOR CPS133 WITH CONNECTOR VCRP133, WHICH IS PART OF BACKUP ALARM ASSEMBLY.
- CONNECT CONNECTOR CPS135 WITH CONNECTOR VCRP135, WHICH IS PART OF STROBE LIGHT ASSEMBLY.
- ROUTE WIRES FROM CONNECTOR CPS133 AND CPS135 AS FOLLOWS:
 - ROUTE RED WIRE W10-F AND W10-G TO KEY SWITCH AND CONNECT TO "START" POSITION.
 - ROUTE RED WIRE W724-A AND W724-AA ALONG THE MAIN WIRE HARNESS TO CONNECTOR CPS05 ON AC CONTROLLER AND INSERT WIRE W724-A RED INTO CONNECTOR CPS05, POSITION 17.
 - INSULATE AND SECURE WIRE W724-AA RED.
 - CONNECT CONNECTOR TBF36 WITH CONNECTOR TBM36.
 - USE TY-WRAPS TO SECURE BOTH WIRES TO THE MAIN WIRE HARNESS.

CONDITION SETTING INSTRUCTIONS:

- ENTER TECHNICIAN PROGRAMMING MANU.
- GO TO GENERAL ITEMS.
- SET TO ACCESSORY CONDITION.
- SAVE AND EXIT.

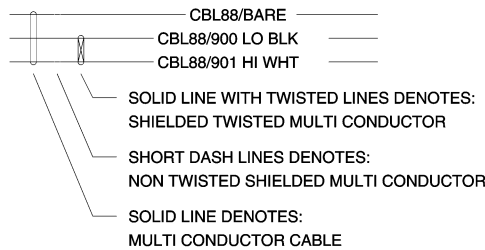

8543142
 Sheet 4 of 8
 Revision 0

BS080285

Figure 8. Schematic / Wiring Diagrams (Sheet 4 of 8)

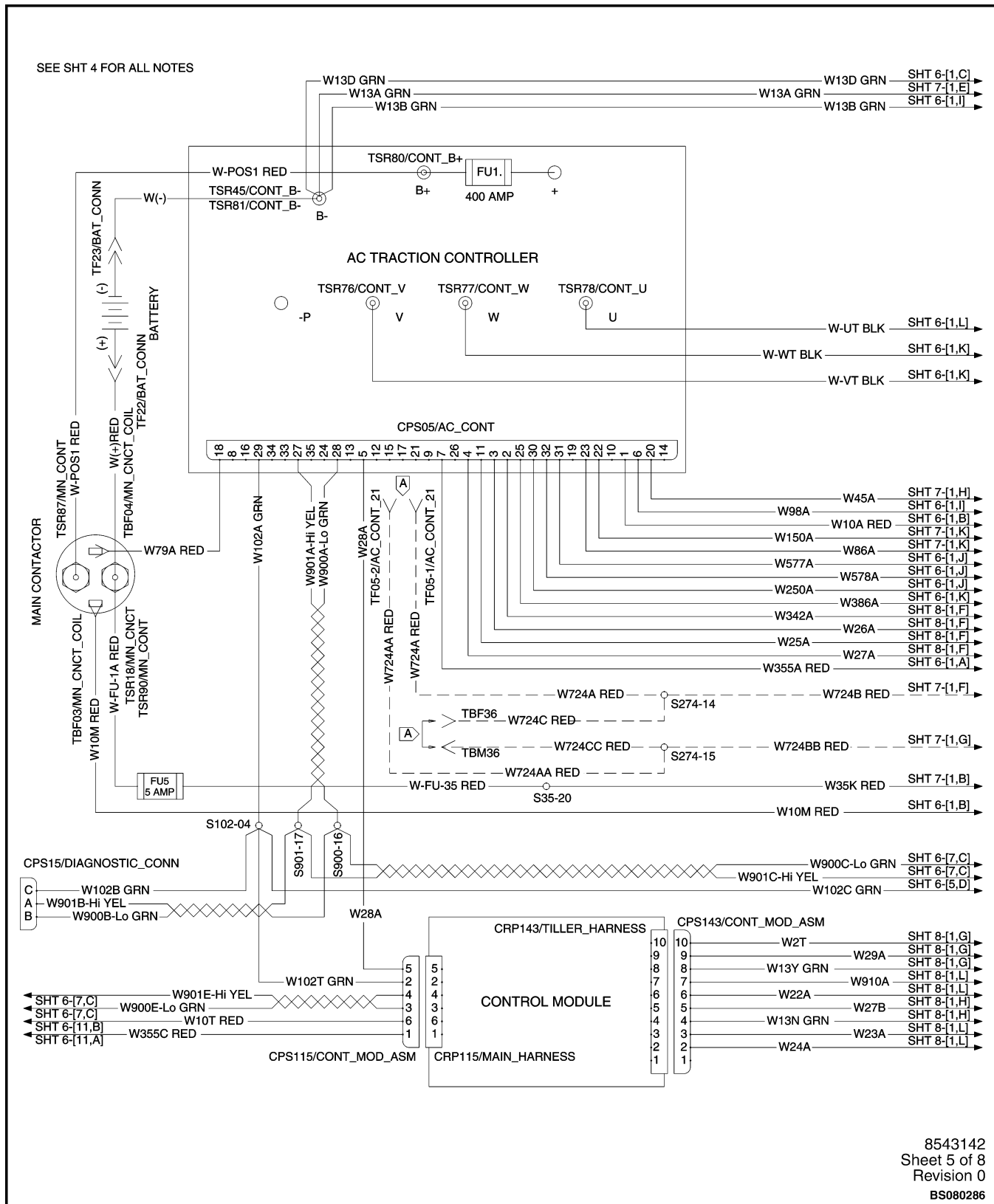
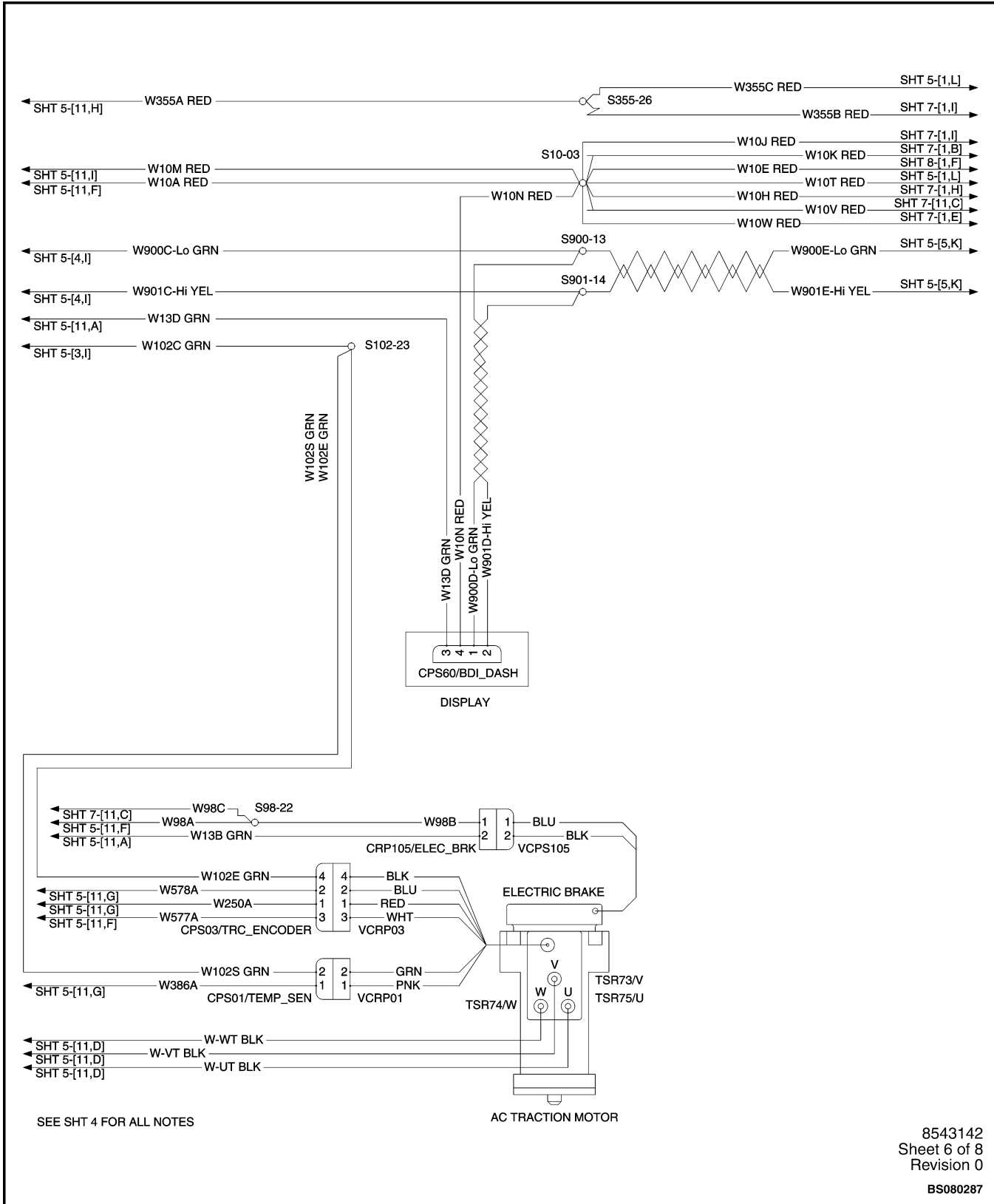
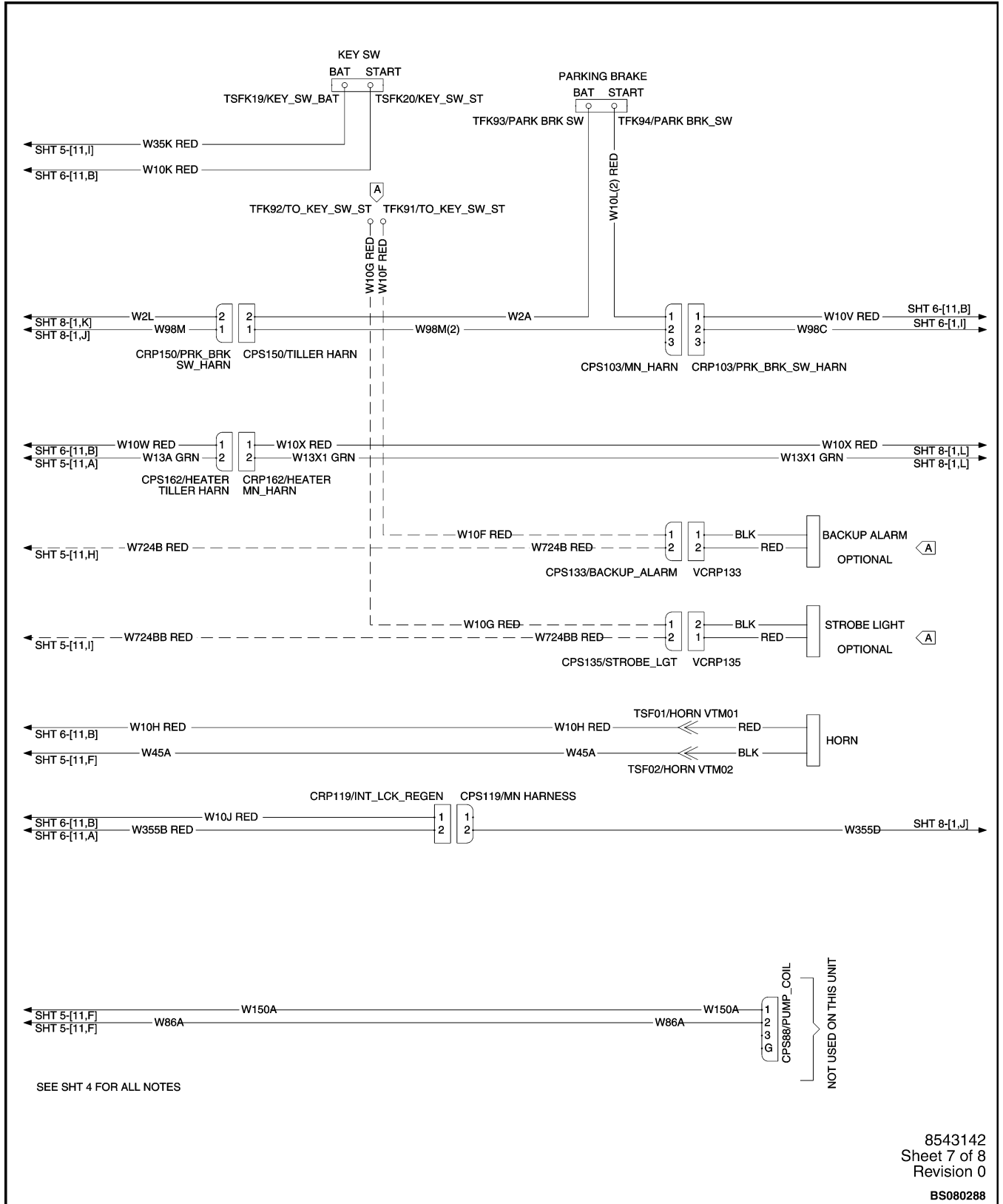

Figure 8. Schematic / Wiring Diagrams (Sheet 5 of 8)



8543142
 Sheet 6 of 8
 Revision 0
 BS080287

Figure 8. Schematic / Wiring Diagrams (Sheet 6 of 8)



8543142
 Sheet 7 of 8
 Revision 0

BS080288

Figure 8. Schematic / Wiring Diagrams (Sheet 7 of 8)

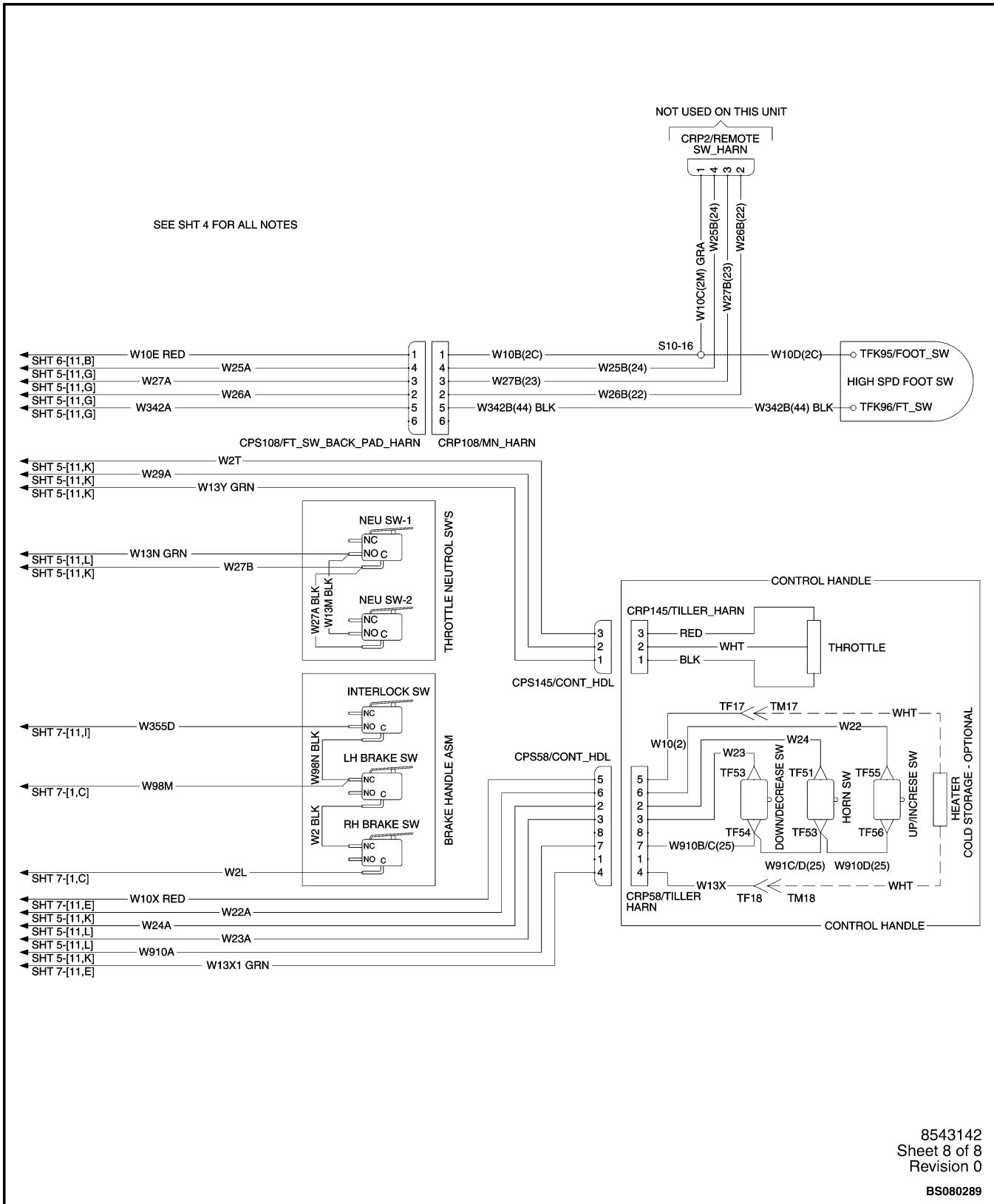

8543142
 Sheet 8 of 8
 Revision 0

BS080289

Figure 8. Schematic / Wiring Diagrams (Sheet 8 of 8)